

Northfast Derrie Dry Ridge System 3m

Fixing Instructions

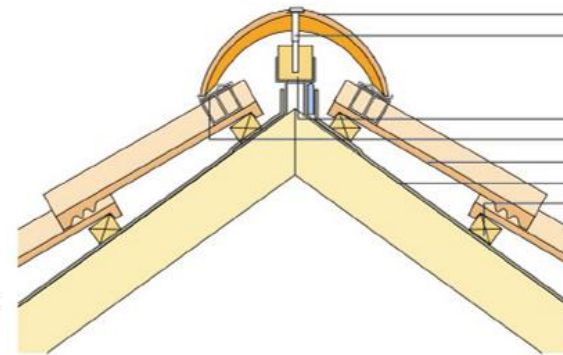

Derrie Dry Vent Ridge Systems, 4.5m

- 450mm Concrete Ridge Tile (Multi Ridge, Half Round Ridge or Universal Angle Ridge)
- Stainless-steel screw with rubber washer into jointing bracket

- Ridge batten 50mm x -* (see ridge batten height table)
- Vented profile filler unit
- Derrie standard tile (profile as selected)
- Roof underlay cut at ridge apex
- 50mm x 25mm tiling batten

*** RIDGE BATTEN HEIGHT TABLE**

Tile profile	Rafter pitch	Batten height mm
Double Roman	22.5° - 35°	75
	36.0° - 50°	50
Flat Tiles	22.5° - 30°	50
	31.0° - 55°	25

1. Lay the underlay and batten the roof in the normal manner, but do not fix the top tiling batten at this stage. The top courses of underlay must be cut to finish 15mm short of the ridge apex to allow for a clear opening for ventilation of the roof space. Ensure that the top tiling batten will be as close to the ridge batten as the tile nibs will allow. Bend the ridge batten straps at the centre mark, to suit the pitch of the roof. Position them centrally over the roof apex, at not more than 800mm centres, and secure to the rafters or trusses with 30mm Clout head nails (only through the sections with 2 nail holes). Bend the free sections of the ridge batten straps, where marked, vertically upwards on both sides of the ridge.

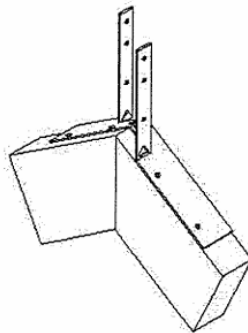

2. Select a combination of tiling battens to achieve the correct height, (see table overleaf) and position them between the upturned sections of the straps. Bend the straps over the ridge batten and secure with clout head nails.

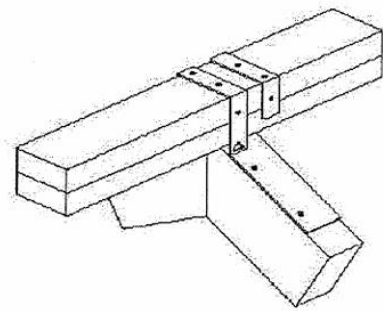

3. Lay and fix the top courses of tiles in the normal way, including all dry verge or mortar bedded verge tiles/slates. Ensure that all fixing of tiles/slates is in accordance with Northstone fixing recommendations and 5534

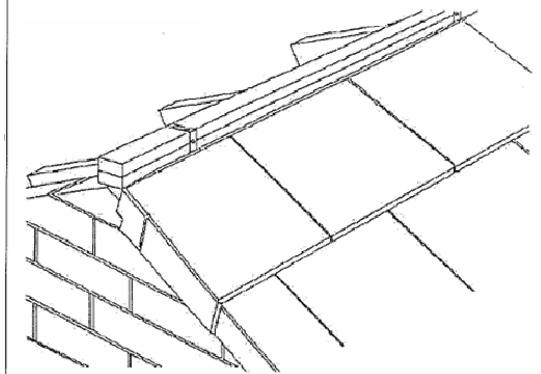

5. Start by clicking the ventilation units together, end to end, and positioning them either side of the ridge, making sure they are facing the correct way. (Note that the arrows on the ventilation units point towards the ridge). It may be necessary to cut the final pieces to suit the ridge length

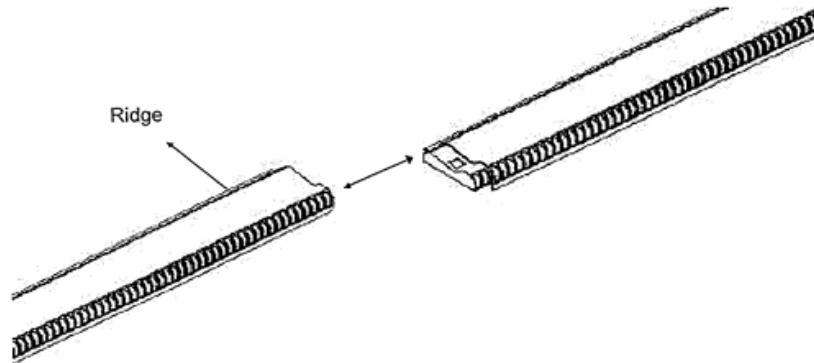

6. Start by fitting a block end ridge on top of the ventilation units and position a ridge seal under the open end. Fix the block end of the ridge tile securely with a screw nail. Always ensure that the screw nail penetrates the ridge batten by a minimum of 25mm. Continue fixing in the same way along the entire length of the ridge, cutting the final ridge to fit. Always work from the gable towards an abutment. Do not attempt to secure cut ridges less than 20mm long, in this case cut the last 2 ridge tiles. Never place cut ridge tiles at the end of the ridge line.

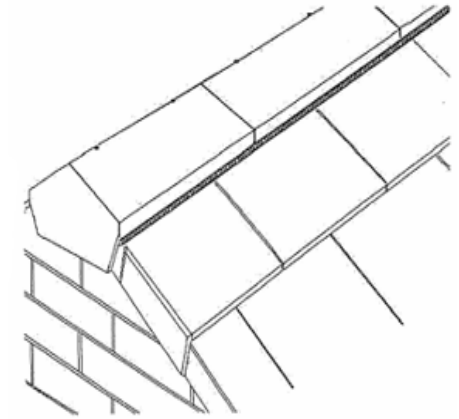

Pack Contents:

20 No Profile Fillers for Derrie
Derrie Tiles



1. Follow all the fixing instructions in the accompanying pack of Dry Fix Ventilated Ridge, (packed separately) until you are ready to install the 900mm ventilation units.
2. Click the individual profile fillers into the ventilation strips 3 per strip. Then click the ventilation strips together end to end and position to each side of the ridge. Make sure they are facing the correct way – for ease of use both the profile fillers and the ventilation strips have arrows which must point towards the ridge.
3. Continue with the fixing procedure for the ridge unions, following all good roofing practices and the requirements of National Building Standards



For further technical advice please ask for our data sheet
and assembly document, or contact:



Roadstone Ltd Retail Shop Belgard Road Dublin 24 Tel: 01 4041275	Northstone Ltd Retail Shop Creagh Road Toomebridge Tel: 0044 28 7965 1317	Roadstone Ltd Retail Shop Classis Ballincollig Co Cork Tel: 021 4800118
--	---	---



northstonematerials.com

roadstone.ie